



CFL6

BEARTIGHT PROTECTION



QUOTE

HAUL-ALL EQUIPMENT LTD WASTE & RECYCLING SOLUTIONS



Haul-All Equipment specializes in the design, manufacture, sale and support of waste and recycling systems including storage containers, collection vehicles and transfer stations.

- 40+ years experience
- 30+ Patents & Trademarks
- IGBC Certified Products

Our focus is on delivering high-quality products and pioneering advancements in the industry.

THE CFL6:

STREAMLINED COMMERCIAL WASTE MANAGEMENT

The CFL6 front load commercial bin is designed for accessibility, with a low loading height that accommodates all users.

Available in versatile configurations, it features an easy-to-use door mechanism that enhances user convenience and efficiency in waste disposal.

Built with durable galvanized steel and finished with a high

gloss powder paint, the CFL6 promises lasting performance in any commercial setting. Its construction is complemented by a Crosstube Bumper for added impact resistance, ensuring the bin's longevity.

Delivered ready to use or in nested form for cost-effective shipping, the CFL6 is straightforward to set up. With its

practical dimensions and significant capacity, it meets the needs of diverse commercial environments.

Choose the CFL6 for an efficient, durable, and user-friendly solution to commercial waste management in your project or community.

TRUSTED BY



BC Parks





CFL6

The CFL6 is an automated bear and animal resistant front load container with nestable hopper and lid for storage and freight efficiency. Front load protection from the most reliable and experienced company in the industry. 36 inch low loading height and auto release unloading door.



OVERVIEW

The CFL6 is manufactured from galvanneal steel panels for strength and unmatched rust resistance. The container is further protected by powder paint, and optional armorthane coating, which provide unbeatable impact resistance.

Sturdy construction, bear proof latches on loading doors, and fork-actuated release on unloading door eliminate access to dumpster-diving bears and other critters. The CFL6 is a dumpster like no other.



QUOTE

DISCOVER THE FEATURES THAT MAKE CFL6 YOUR BEST CHOICE!

AUTO RELEASE UNLOADING DOOR



BEAR LATCH LOADING DOORS



DESIGNED FOR DURABILITY & LONGEVITY



STOCK COLOURS



● Neufeldt Green

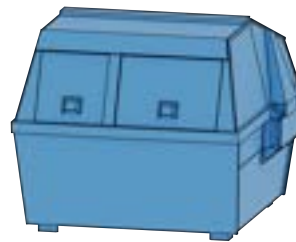

● Grabber Blue

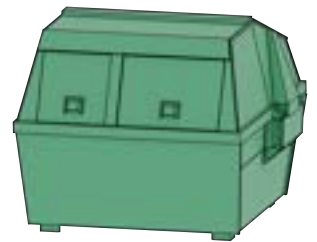

● Forest Green



● Orange



● Baron Red



● Black

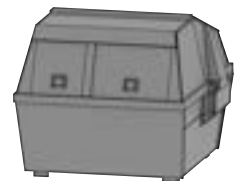



● Pewter



QUOTE

SPECIFICATIONS

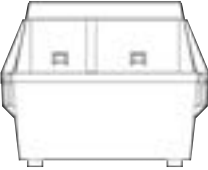
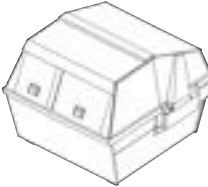
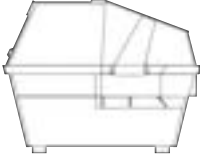
CFL6

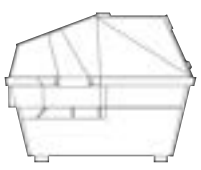
CAPACITY	HEIGHT	LENGTH	WIDTH	CONSTRUCTION	HINGES & LATCHES	PAINT
4.6 cubic metres (6 cubic yards)	1676 mm (66 inches)	1867 mm (73-1/2 inches)	2083 mm (82 inches)	Galvanneal Steel	Stainless Steel	Powder Coat
						

**CONTACT OUR TEAM
FOR TAILORED ADVICE & PRICING**

1-888-428-5255

SALES@HAULALL.COM

BOOK A CALL

REQUEST A QUOTE

